

Ime

Vježba 1.dio



1. Nadopuni niz

7, 8, _____, _____, _____, _____, _____, _____

25, 24, _____, _____, _____, _____, _____, _____

27, 28, _____, _____, _____, _____, _____, _____

100, 99, _____, _____, _____, _____, _____, _____

2. Pažljivo pripazi kako se nastavlja niz.

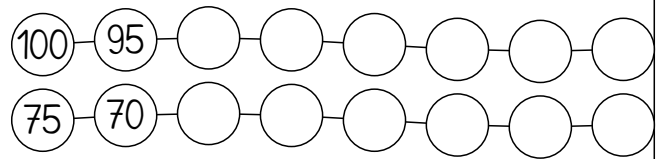
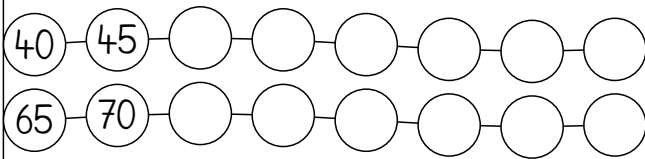
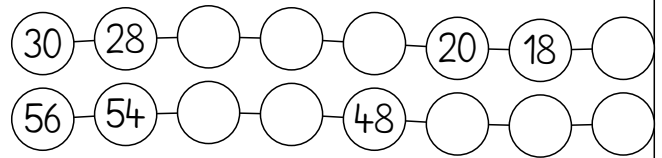
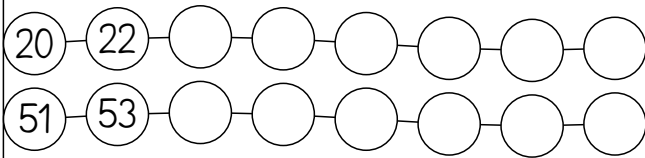
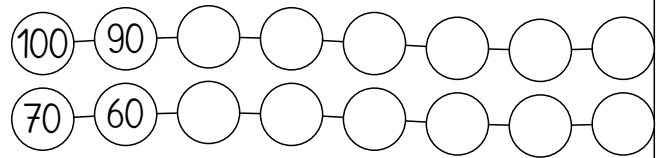
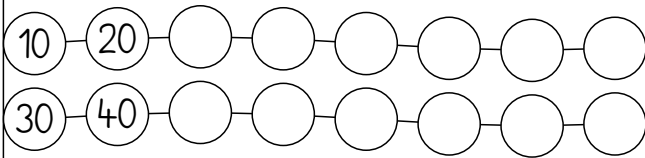

3. Upiši prethodnike i sljedbenike.

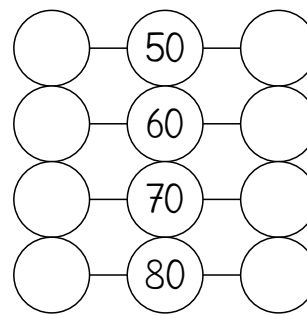
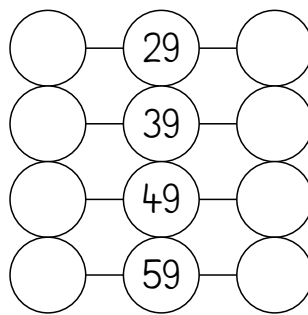
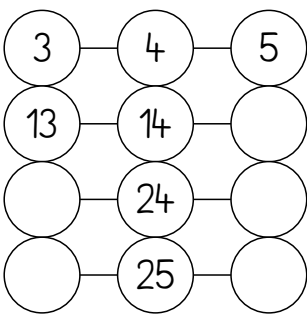

4. Nastavi niz po 5.

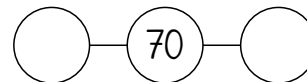
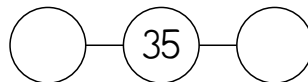
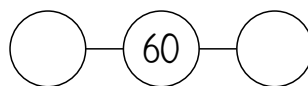

⊕ Tko želi.

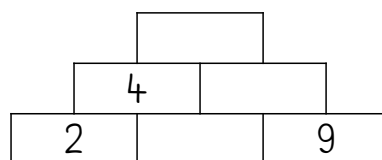
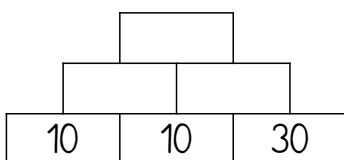

5.

Oboji koliko je zapisano, možeš desetice obojiti drugom bojom.

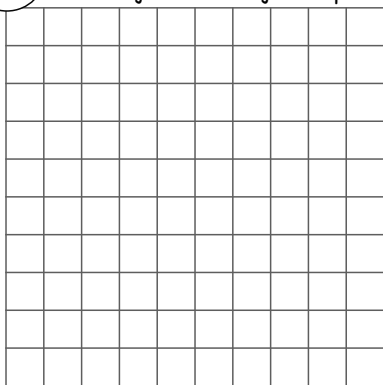

63

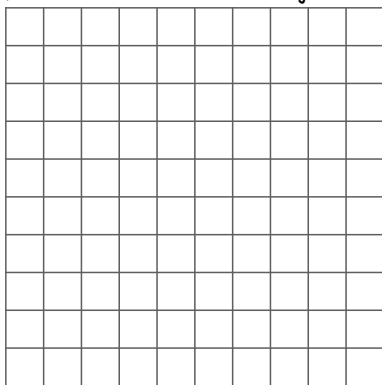

32

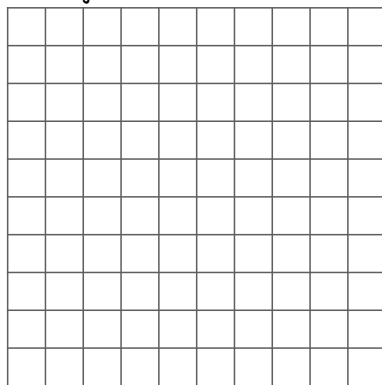

78

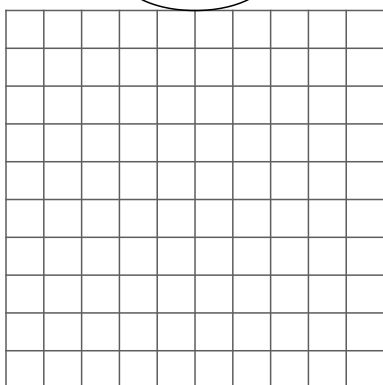

12

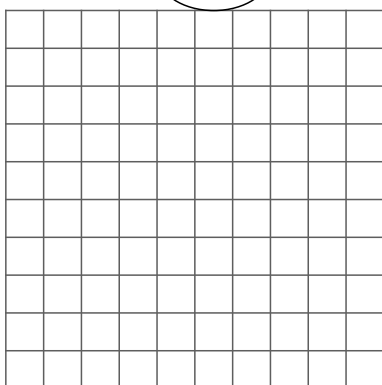

24

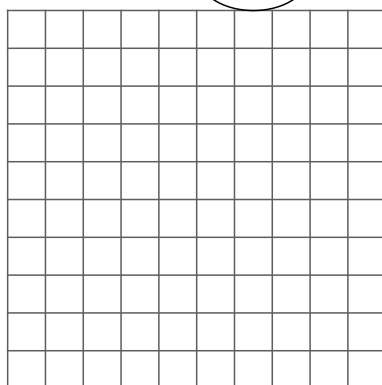

81

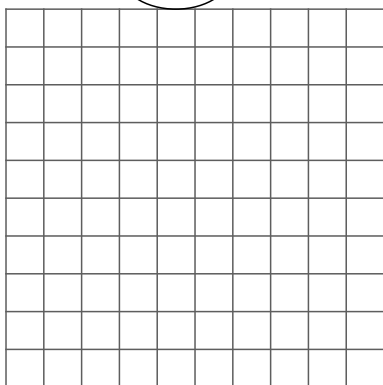

46

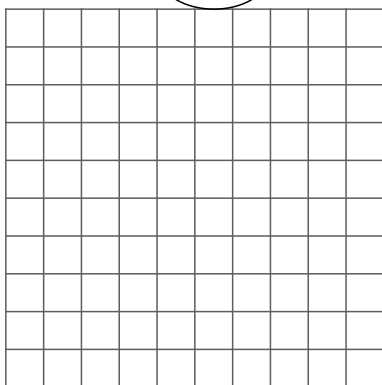

9

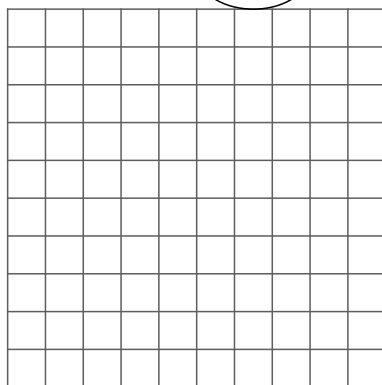

55

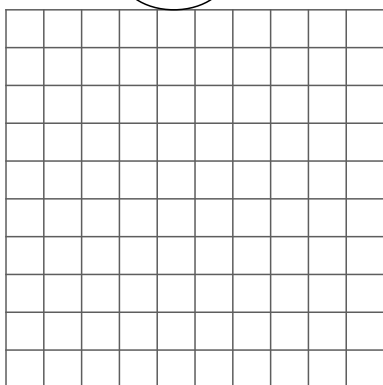

76

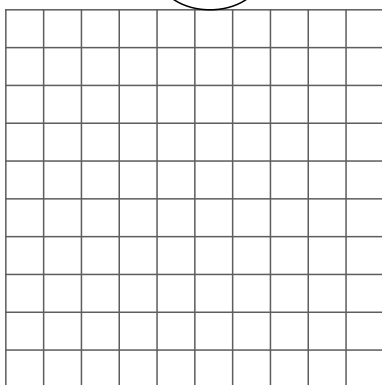

89

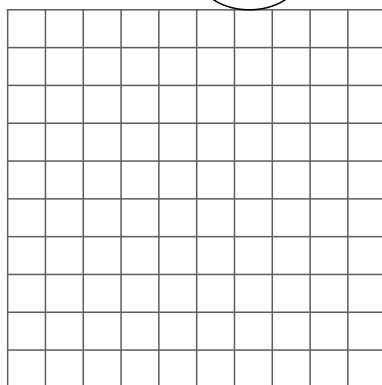

94